

Maßblatt Stabtrommel

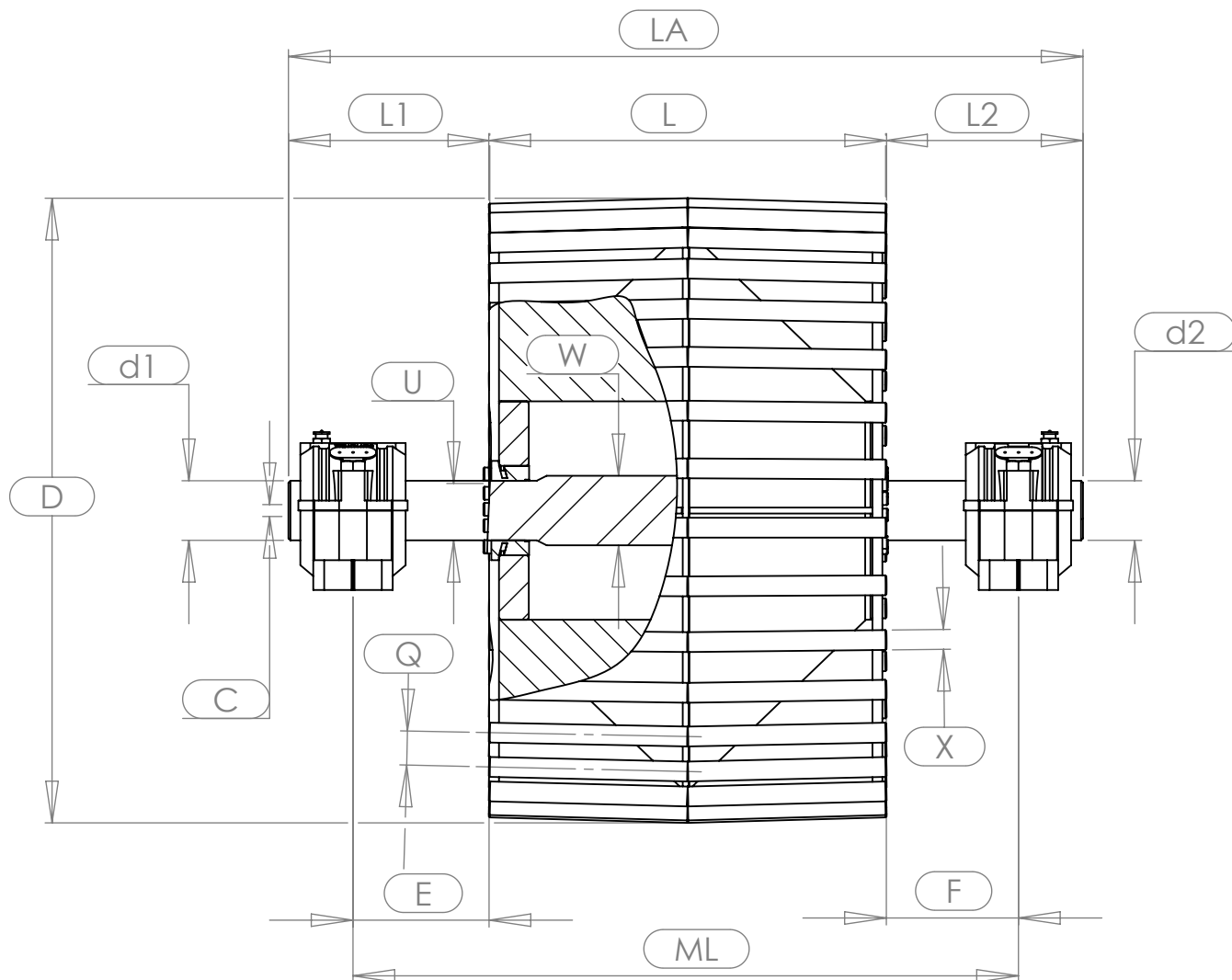

©jachmann GmbH Fördertechnik

Daten -Stabtrommel						
D	mm					
L	mm					
W	mm					
U	mm					
d1-d2	mm				C - Gewinde M . . .	
LA	mm				E	mm
L1	mm				F	mm
L2	mm				ML	mm
Anzahl Stäbe					Anzahl Stäbe	
Stab Ø - X	mm				Q - Mitte-Mitte Stab	
Kontaktfahne	ja	<input type="radio"/>	nein	<input type="radio"/>	eins.	<input type="radio"/>
					beids.	<input type="radio"/>
Stehlager	ja	<input type="radio"/>	nein	<input type="radio"/>		
Innenlager	Rollenlager	<input type="radio"/>	Kugellager	<input type="radio"/>		

Jachmann GmbH Fördertechnik
 Tel.02683-7033
 Fax.02683-7809
info@jachmann-foerdertechnik.de