

Unterband- Lenkstation

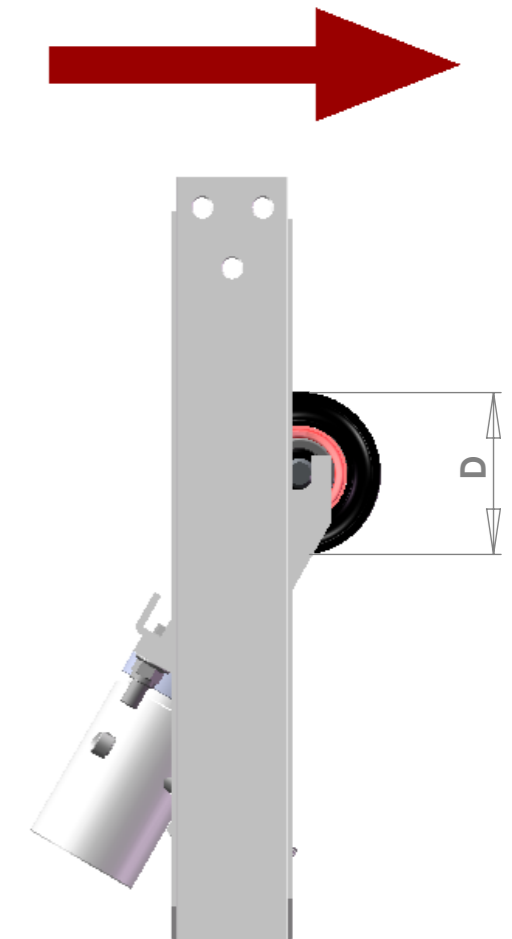
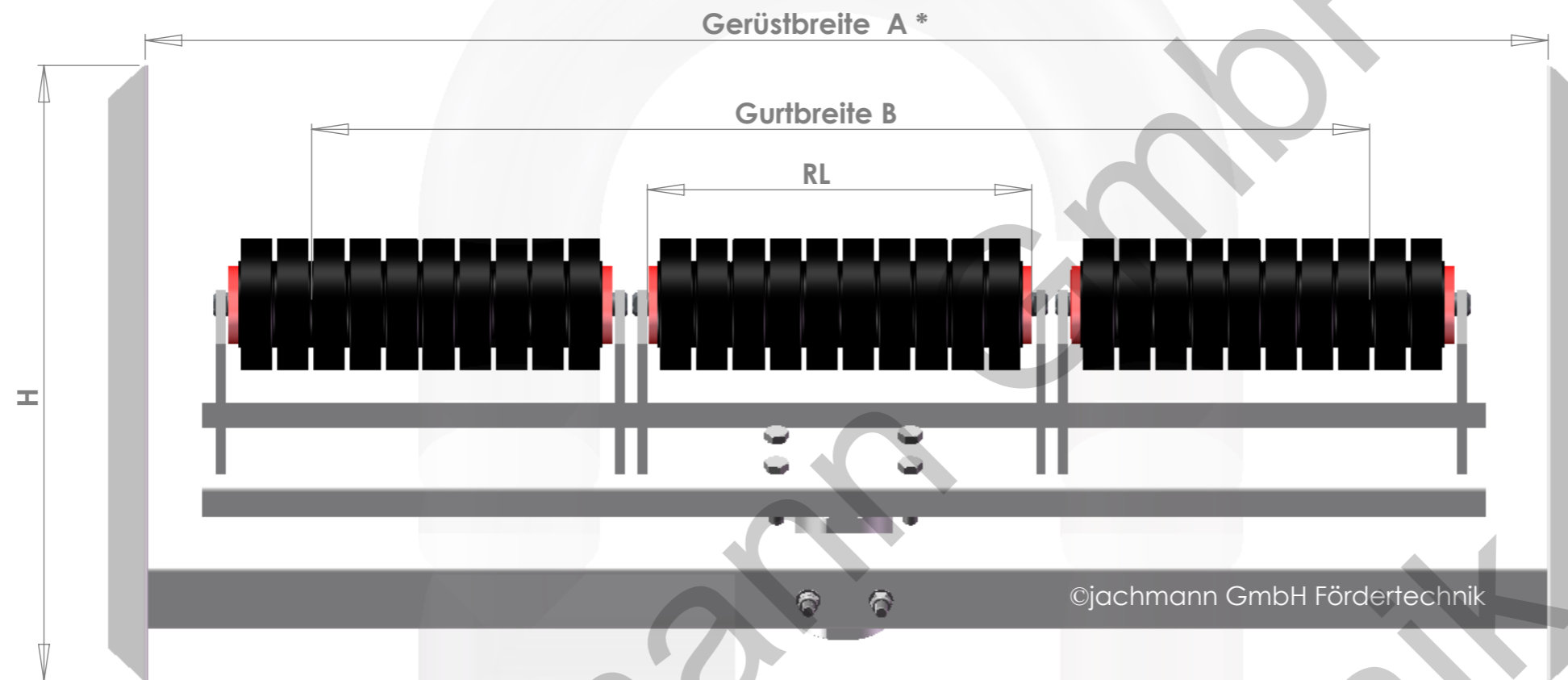

A *	B	RL	D	H*
800	500	200	89	470
950	650	250	89	470
1150	800	315	108	470
1350	1000	380	108	470
1600	1200	465	108	470

jachmann gmbh fördertechnik
 Industriepark Nord-25B 53567 Buchholz
 Tel. 02683-7033 - Fax.02683-7809
 mail: info@jachmann-foerdertechnik.de